

SIMPLE ASSEMBLY INSTRUCTIONS FOR CURTISS A-18 ARMY ATTACK PLANE

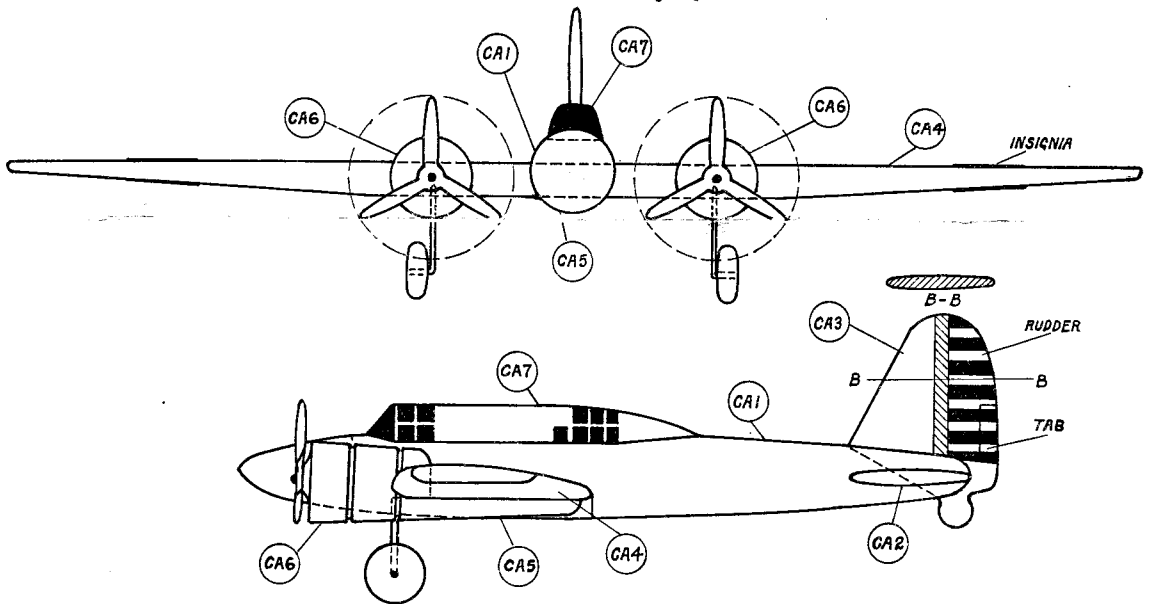

Read instructions through and compare all parts with the drawings before you start to assemble this model. You will be much more pleased with the finished result if you follow instructions in the order in which they are given. Mix only a small quantity of the glue at a time. It is not necessary to use glue clamps when assembling StromBeckKer Models.

Glue the coarse sandpaper to one end of the 1/8"x1"x5" wood stick, and use this as a file to round edges of fuselage, wing and tail parts.

Sand fuselage (CA1) and glue on tail parts (CA2 and CA3). After the glue has thoroughly dried, sand the parts to shape, rounding the edges as shown at cross sections AA and BB on drawings, with coarse sandpaper and finish with fine sandpaper.

Round ends of wing (CA4) at C, also front and rear edges, with the coarse sandpaper and finish with the fine. Glue onto fuselage and be careful to get it square and in the center.

Next glue on filler block (CA5) under the wing. Sand joints after glue has dried.

Sand front and rear ends of pilot's cabin (CA7) to the shape shown on drawings. Then sand underside to fit recess on fuselage and glue in place.

Assemble propellers to engines (CA6) with the nails. If necessary sand sides of motors to fit slots in wing and glue in place.

Assemble the two wires to landing gear wheels. Put a little glue in the holes underneath the motors and insert wires. See drawing.

(Over)

Do not ask your dealer to supply missing parts as he does not carry these in stock. Use coupon below and order direct from us for prompt service.

All sets are carefully packed, but if you find a shortage or defective part, fill out this slip and we will send it without cost.

Part numbers will be found on drawings. Model number is on flap at end of carton.

(Write plainly)

Part Number.....Model Number C7

My name is.....

House or Box No.....

City and State.....

Paste this slip on back of 1c post card. Address card to:
STROMBECK-BECKER MFG. CO.
MP DEPT. Moline, Ill.

Many model makers prefer to finish their models in natural wood finish, using either shellac or clear lacquer. If you wish to paint your model in the regular Curtiss colors, use aluminum paint. Show windows, doors, ailerons, elevators, etc., by

drawing these with pen and ink. Use only India drawing ink as other inks may rub off.

Put shield and insignia on last. See drawing.

