

ENGINE REVIEW

by PETER CHINN

WEBRA T4-40 FOUR-STROKE

SPECIFICATIONS

Type: Single-cylinder, glowplug ignition, four-stroke-cycle with toothed-belt driven cylinder-head rotary valve. Twin ball bearing crankshaft.

Checked Weight: 381 grams (13.4 oz) including muffler

Displacement: 6.442cc (0.3931 cu in.)

Bore: 21.0 mm (0.8268 in.)

Stroke: 18.6 mm (0.7323 in.)

Stroke/Bore Ratio: 0.886:1

Measured Compression Ratio: 7.0:1

Performance Data:

Power Output, net: 0.44 bhp at 12,200 rpm

Torque, net: 46 oz-in. at 6,000 rpm

Equivalent b.m.e.p.: 92 lb/sq in.

Specific Output, net: 1.12 bhp/cu in.

Power/Weight Ratio, net: 0.53 bhp/lb

Manufacturer: Webra Modellbau GmbH, D-8581 Weidenberg, West Germany.

U.S. Distributor: Circus Hobbies, 3132 S. Highland Dr., Las Vegas, NV 89109.

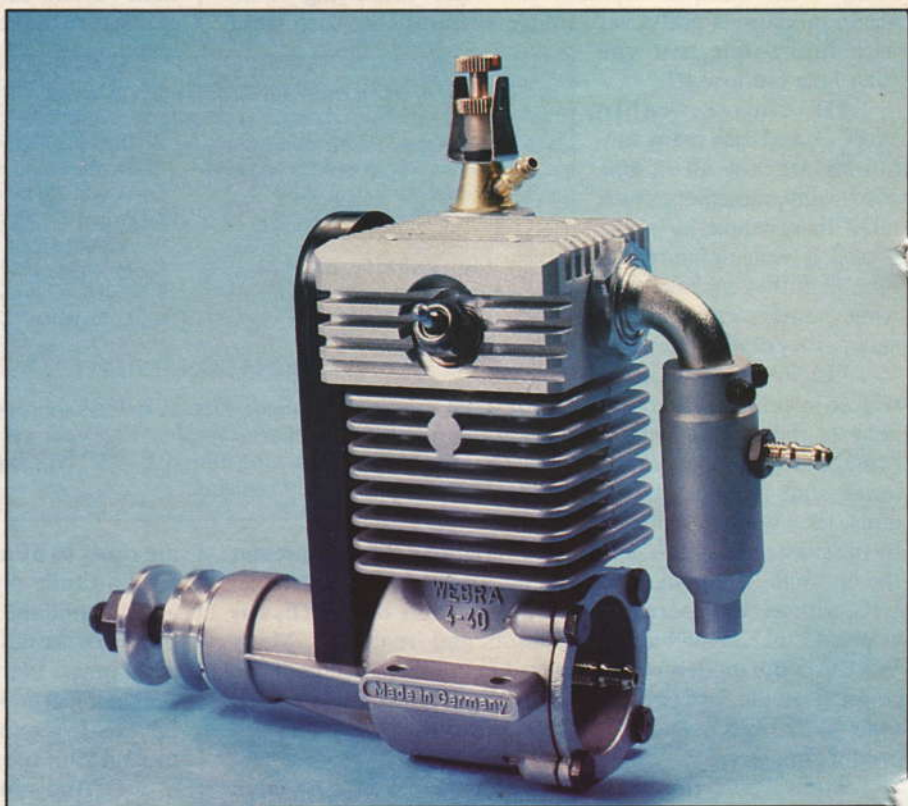

Engine comes complete with muffler, which also provides pressure take-off for fuel tank. Fitting in backplate is crankcase breather.

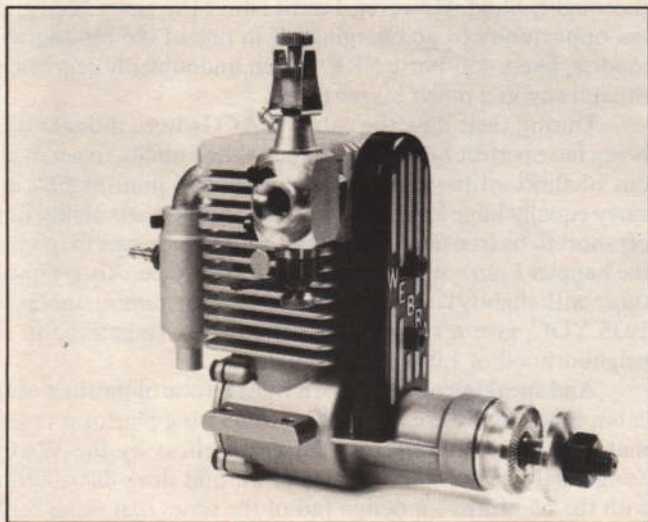

Webra's T4-40 is quite simple, no cams, rockers, pushrods, gears.

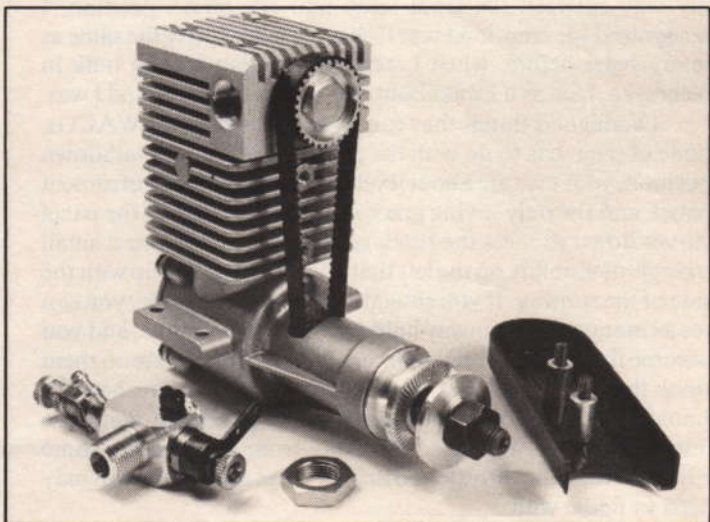

Simple toothed belt drive to rotary valve in head eliminates need for separate timing gears. Carburetor is Webra TN type.

MOST R/C fliers who buy four-stroke-cycle engines, rather than two-strokes, do so because they prefer the four-stroke's quieter, lower-pitched exhaust note and/or are attracted by its extra working parts and apparently greater realism. But there are probably some "non-engine-minded" modelers who regard the addition of gears, cams, pushrods, rocker-arms, poppet valves, springs and tappet adjusters with some suspicion and as potential sources of trouble with which they may or may not feel able to cope.

Such apprehensions are not really justified. Most current model four-strokes are very reliable, but if simplicity is what you are looking for, look no farther: the recently released Webra T4-40 eliminates all the parts mentioned above and is by

far the simplest four-cycle engine offered to date.

The T4-40 is a rotary-valve engine. There are, of course, other rotary-valve four-strokes on the market, but none is quite so basic as the T4-40. For example, the British RVE and Austrian HP have vertical axis rotary-valves that are shaft driven, from a rear drive take-off, via bevel gears in the crankcase plus spur gears in the cylinder head. Webra's original four-stroke, the rugged .87 cubic inch T4 model, also with vertical axis rotary-valve, eliminates the rear take-off and vertical shaft in favor of a toothed belt and pulleys from the crankshaft main journal, but still requires bevel gearing to drive its vertical axis conical type rotary-valve.

The obvious way to eliminate bevel

gearing was to substitute a horizontal axis rotary-valve parallel to the crankshaft and connected to it by means of a toothed belt. And, by using a larger pulley on the valve, the rotary-valve could be made to rotate at the required speed without separate reduction gearing. This was the configuration chosen by Webra for their new 40 size four-stroke as dealt with here. The T4-40 is not the only production engine to use a horizontal cylindrical rotary-valve. The first was the British Condor 90 two years ago, since joined by the 120 model (see *M.A.N.* November 1983 issue), but here the belt drive is taken from a separate, crankpin driven, ball-bearing mounted rear shaft, rather than

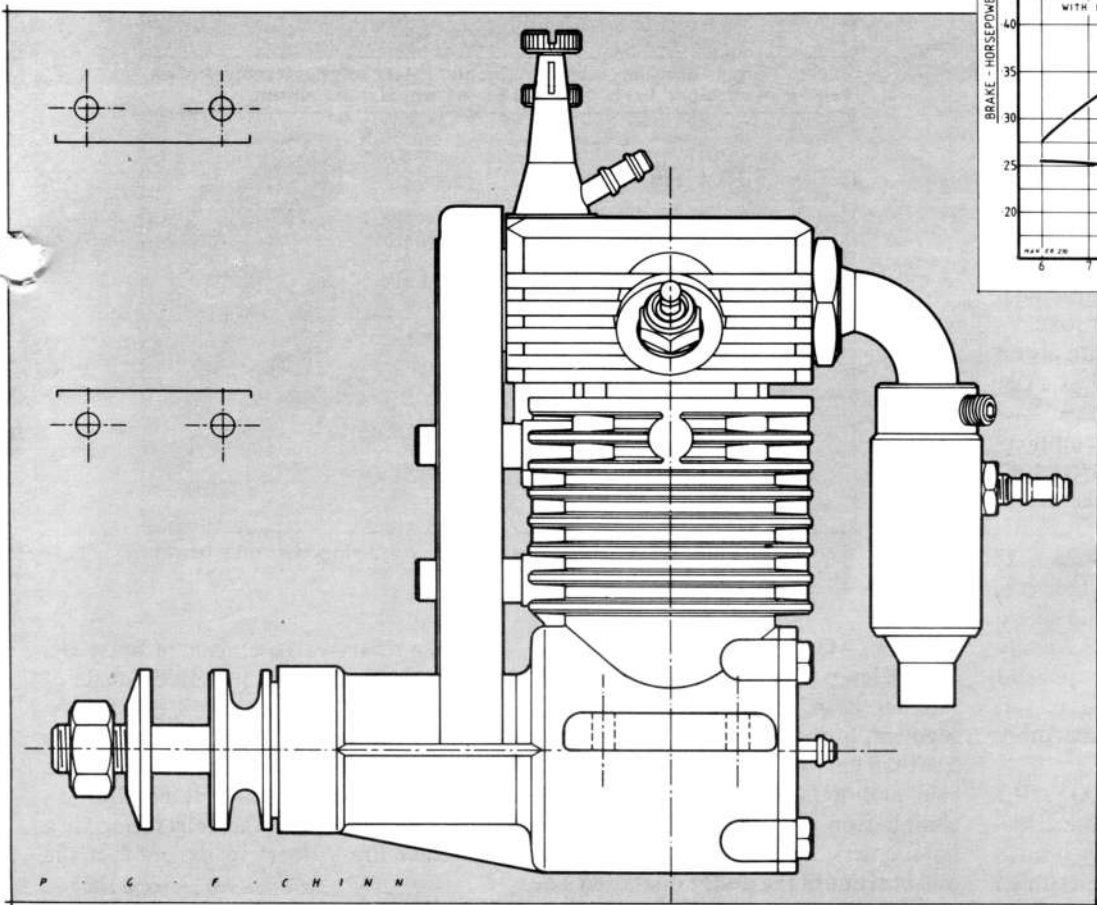
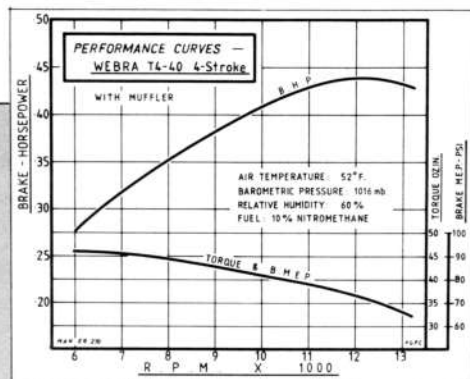

directly from the crankshaft as in the T4-40, which, of course, eliminates the need for an extra shaft and bearings.

An examination of its component parts reveals that the T4-40 is really no more complicated than, say, a rear rotary valve two-stroke motor. Let's take a closer look.

MAIN CASTING. This is an aluminum pressure die-casting comprising the crankcase, front housing and full-length cylinder casing. The crankcase has an external diameter of 33 mm, a wall thickness of 2 mm and has the usual beam mounting lugs, with their mounting faces on the horizontal centerline. The cylinder casing has large square cooling fins.

CRANKSHAFT AND BEARINGS. The hardened steel one-piece counter-balanced crankshaft has a $\frac{3}{8}$ -inch diameter main journal, a 7 mm diameter front journal and a 5 mm diameter solid crankpin on a 7 mm thick crankweb. The shaft runs in an Imperial size ($\frac{3}{8} \times \frac{7}{8}$ inch) 8-ball brass-caged ball journal bearing at the rear and a Metric (7x19 mm) shielded ball-journal bearing at the front. Just in front of the rear bearing, the shaft has 15 gear teeth cut into its $\frac{3}{8}$ inch diameter for the drive belt and there is a 7 mm wide slot in the top of the housing through which the toothed belt passes. The belt is aligned on the shaft teeth by floating sleeves fore and aft.

CYLINDER LINER & PISTON ASSEMBLY. A chromed bore brass cylinder liner is used. It has a 1.0 mm thick wall and is located, in the usual manner, by a flange at the top. The flange is 3 mm thick and has a 26 mm outside diameter. The cylinder bore tapers slightly, the bore being reduced approximately .001 inch at the top, to combine effective piston seal at TDC with reduced frictional loss over the lower part of the stroke.

Machined from an appropriate piston alloy, the short skirted piston has a flat head and is equipped with a single low-pressure Dykes type (L-section) compression ring. A solid 4 mm diameter full-floating wristpin is fitted to the piston and is retained by wire circlips.

The forged alloy connecting-rod is 32 mm (1.72 x stroke) between centers. It is bronze bushed at its crankpin end where it is provided with three oil holes equally spaced around its bore. The wristpin end of the rod is plain, with a generous oil slit. The complete piston and rod assembly checked out at 11.2 grams.

CYLINDER HEAD & ROTARY VALVE. The solidly proportioned machined aluminum alloy cylinder-head is 22 mm deep and is tied to the cylinder



Parts of T4-40. Engine features Dykes-ringed piston running in chromed brass sleeve. Note splines on crank for toothed belt drive.

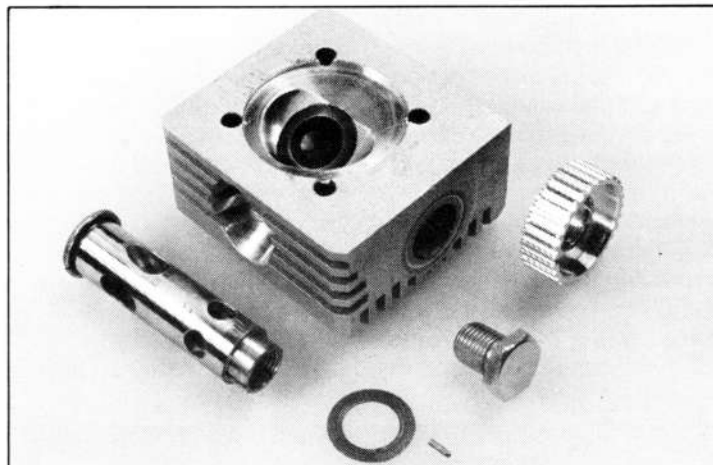

Webra's highly unusual cylinder head and rotary valve assembly. Rotary valve is of chromed brass. Toothed timing wheel is aluminum.

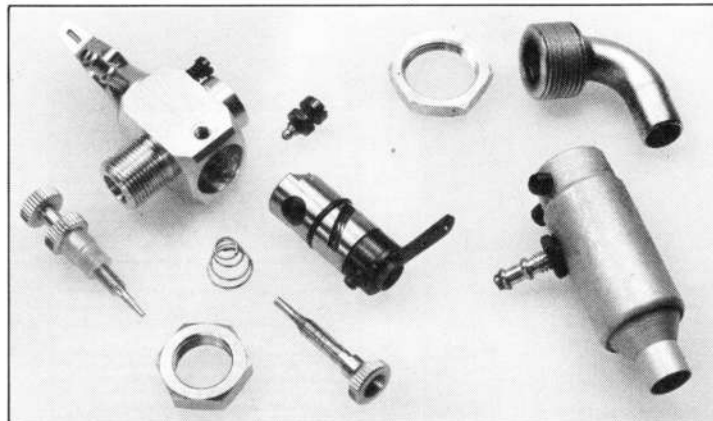

Carburetor parts, left, showing two needles and O-ringed throttle barrel. Exhaust elbow and muffler assembly on right.

with four M3x0.5 hex socket cap screws, 25 mm long. No head gasket is used. The internal head shape consists of a flat segment, forming a squish area of rather less than half the piston area, on the right side and a fairly deep wedge shaped chamber on the left side. The glowplug hole enters at an angle through the outside edge of the wedge on the left side.

The rotary-valve is made of brass and hard-chrome plated. It has a diameter of 10 mm and two oval ports; one for the inlet and one for the exhaust. These register, in turn, with a 5 mm wide 8.7 mm long port leading into the combustion chamber. This port is actually formed in a circular brass insert in the roof of the

(Continued on page 100)

ENGINE REVIEW

(Continued from page 20)

combustion chamber wedge, where it is retained in the aluminum head by an O-ring. The rotary valve is located well above the combustion chamber wedge and the effective chamber shape, therefore, combines the wedge with an 8.7 mm diameter, 3 mm deep depression between the surface of the wedge and the valve surface.

The valve is bored 6.5 mm i.d., separately from each end, to register with the inlet and exhaust ports. Taking the inlet first, the carburetor is screwed into the right-hand side of the head at the front. From here, the fresh charge enters the head through a short 6 mm diameter passage in the head and then into a narrow annular chamber surrounding the valve. The charge is then transferred to the front (inlet) 6.5 mm i.d. passage in the valve through four 4.5 mm diameter holes spaced around the front end of the valve.

Exhaust gas enters the rear (exhaust) 6.5 mm passage in the rotary valve through the exhaust port and is simply ejected horizontally rearward into a right-angled exhaust elbow that is screwed into the rear of the head.

A check on the valve timing of the test engine yielded the following (approximate) figures. Inlet opens 20 degrees before top dead center (TDC); inlet closes 30 degrees after bottom dead center (BDC). Exhaust opens 30 degrees before BDC; exhaust closes 20 degrees after TDC. These indicate moderate inlet and exhaust periods, each of 230 degrees of

crankshaft rotation and a valve overlap of 40 degrees.

The chromed valve runs directly in the head material except at the extreme front end where support is provided by a bronze bushing. The valve is located axially by a 12.4 mm diameter flange at the rear and by the valve drive pulley at the front. The flange is recessed well within the head to allow room for the exhaust elbow to be screwed into it.

ROTARY VALVE DRIVE. At its front end, the rotary valve is reduced to 8.5 mm diameter for mounting the drive pulley and is internally threaded M7x0.75 for the hexagon headed brass screw that retains the pulley. The pulley is keyed against rotation with a simple round key—actually a tiny steel pin 1.0 mm diameter and 4 mm long. The pulley itself is of aluminum, 19 mm diameter, with 30 teeth, 6.7 mm wide.

The toothed belt is 5 mm wide and is protected by a stamped aluminum cover that attaches to two lugs between the cylinder fins with 3 mm cap screws and aluminum tube distance-pieces. Belt life should be considerable, since the work that it is called upon to do—i.e., merely revolving a cylindrical member on which there is negligible load—should cause minimum wear. The cover should also contribute to belt life by helping to exclude abrasive dirt that may be picked up on the flying field.

CRANKCASE BACKPLATE. This is a simple pressure casting recessed into the crankcase and secured with four hexagon headed 3 mm screws. It has a center spigot into which a brass nipple is fitted so that surplus oil can be drained away from the crankcase through a suitable length of tubing.

PROP DRIVE ASSEMBLY. This is quite conventional. A machined aluminum alloy driver, with a 21.4 mm diameter serrated face, is mounted on the crankshaft by means of a steel split taper collet. An aluminum prop retaining washer and standard 1/4-28 UNF steel hexagon nut complete the assembly.

CARBURETOR. A Webra two-needle automatic mixture control carburetor is used. This is similar to the type fitted to the Webra Speed-20 R/C two-stroke, except for having a threaded neck and a modified throttle barrel. The modifications include a 5 mm, instead of 6 mm, choke size, plus a bypass hole in the barrel on the downstream side, which comes into effect as the engine is throttled down, its use, apparently, to correct any tendency for the engine to run lean by creating more suction at the jet at reduced throttle

the AIR AND FULL FIGURES

For R/C Aircraft
flexible, super detailed
cut figures

for your oldest,
next creation...
or plane a pilot!

PL FIGURES
N \$12.95
N \$14.95
N \$19.95

RELEASES
S. NAVY \$13.95
S. A.A.F. \$11.95
N \$8.95

(airplane or helicopter)
clipping each figure

FIGURES TODAY
Lawke

Light Way
D 21045
S

AT YOUR HOBBY SHOP



**CIVILIAN BUSTS
NOW AVAILABLE**

1/3 - \$7.95

1/4 - \$6.95

1/5 - \$4.95

**+\$2.00 shipping
each bust**

openings. Effective choke area is approximately 12 sq mm, which is about average for a .40 cubic inch four-stroke. The threaded 10 mm neck of the carburetor allows it to be rotated to any convenient position where it is locked by a plated brass hexagon nut. Like other recent versions of the Webra TN carb, the throttle barrel is now fitted with an O-ring seal to prevent air leakage past the barrel and into the choke.

EXHAUST STUB & MUFFLER. Also of plated brass is the exhaust stub pipe. This consists of an 8 mm o.d. x 6 mm i.d. elbow with a 14 mm diameter threaded portion that screws into the cylinder head and is locked with an aluminum hexagon nut. The small muffler-cum-pressure-chamber, supplied with the engine, slips over the end of the exhaust pipe where it is secured with two headless setscrews. The muffler consists simply of a plain cylindrical expansion chamber having a volume of approximately 4 ml and a generous outlet area of 83 sq mm.

PERFORMANCE. The T4-40 comes equipped with a standard Webra No. 3 glowplug. For breaking-in fuel, the manufacturer specifies Webra Spirit-R 5% or Spirit-S. The former is a castor lubricated mixture containing 5% nitromethane. The latter is a straight methanol and synthetic oil mix. Since Webra's own fuel was not available, we used a 75/20/5 mixture of methanol, castor-oil and nitromethane for breaking in, then switched to 10 percent nitromethane for the tests, which is in line with Webra's recommendations of Spirit-R 5% or Spirit-R 10%. The engine ran well on all these mixtures and so on a straight 80/20 methanol/castor oil mix. Using 10 percent nitro increased rpm by 200-250, depending on prop size. Starting the T4-40 presented no problems. It can be treated in much the same way as a two-stroke -always remembering, of course, not to over-choke before attempting to start. As with any four-stroke that draws its mixture directly into the cylinder from the carburetor, it is normally necessary to choke the carb intake for only one suction stroke with the throttle fully open. Therefore, putting a finger over the intake for a couple flips of the prop (i.e., to make sure that one of those revolutions contains a suction stroke) will usually be quite sufficient. The very first start from cold may occasionally require a second choked induction stroke but, when warm, the engine will invariably respond instantly to a touch of the electric starter without further attention. Needless to say, the engine

starts readily with the throttle set at, or just above, the idle position.

The general handling qualities of the T4-40 were good. The response to the needle-valve was positive without being critical and the test engine showed none of the tendency toward detonation or "ping" that has plagued some four-strokes when leaned out too far, especially when loaded with a big prop. The Webra simply cut out when run too lean. The throttle also worked well although, despite the throttle barrel modification, the test engine did have a tendency to run slightly lean in the mid-range, necessitating a somewhat richer than normal setting of the secondary needle. The position of the carburetor on the cylinder head makes for accessibility and ease of adjustment. The throttle arm is attached to a collar and its angle can easily be adjusted by simply slackening a grub-screw.

The peak power output of 0.44 bhp at 12,200 rpm obtained on test was not quite as high as the exceptional figure earlier claimed for the engine (not an unusual finding in any case) but was, nevertheless, in keeping with the specific output levels for most four-strokes produced to date. Incidentally, our engine was carefully checked over during and after the tests to make sure that everything was in order. All tests were made with the muffler/pressure-chamber fitted to the engine, although checks were made with it removed. It was found that, as a muffler, it lessened noise levels by only 1-2 dBA at one meter, but that it caused virtually no

power loss. It is, however, worth retaining the muffler in that it provides a means of pressurizing the fuel supply.

The T4-40 is notable for its ability to cope with a wide range of prop sizes. The sizes suggested by the manufacturer include 11x6, 10x7, and 10x6. Allowing for normal rpm build-up in the air, these will be turning at between 10,000 and 11,000 rpm in straight and level flight. At the end of the test however, the T4-40 was checked out on twenty larger and smaller props that, respectively, lugged the engine down to full-throttle rpm as low as 6,100 (14x6 Top Flite) and also gave it its head up to over 13,000 rpm. Typical rpm on the most useful sizes, however, included 7,800 on a 12x5 Zinger, 8,700 on a 12x4 Zinger, 9,200 on an 11x6 Power Prop, 9,400 on a 10x7 Zinger, 10,000 on a 10x6 Top Flite, 10,750 on a 10x5 Top Flite, and 12,200 on a 10x4 Zinger.

At the end of the tests, the T4-40 was stripped down to its component parts for examination and photography. All the parts were in good condition (as the photos show) and, as is usual with four-strokes, remained remarkably clean. Incidentally, the original glowplug survived the entire break-in and test program (a second example was tried during and after the tests to check that the performance of the original plug was still up to par) and obviously, the Webra No. 3 plug suits the T4-40 very well.

In conclusion, it is worth mentioning that, if it should become necessary to replace the toothed belt, complete dis-

KNIGHTS of the AIR

GIANT SCALE RETRACTS

Formerly Ancco Mfg. Co.

True scale appearance. Will support models up to 50 lbs. Positive locking, up and down, working oleo struts. Precision machined, all metal lightweight construction. Air/hydraulic controls, 13/16" air

cylinder bore. Gear leg length 11 1/4" from pivot to axle.

Installation drawings, instructions, and air tank are included. Perfect fit for Nosen kits.

RETRACT GEAR

\$220.00 + \$5.00 shipping.
Wheels sold separately.

ORDER DIRECT ONLY

William M. Hawke
7148 Lasting Light Way
Columbia, MD 21045
(301) 730-5596

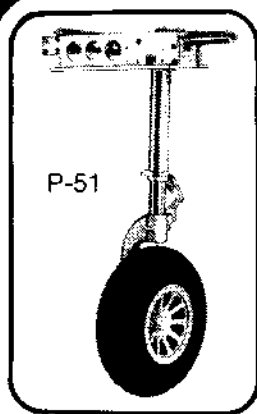

SCALE WHEELS

Real rubber tire, cast aluminum hubs. True scale appearance. 6.5" diameter. Pair of mains - \$35.00 + \$3.00 shipping.

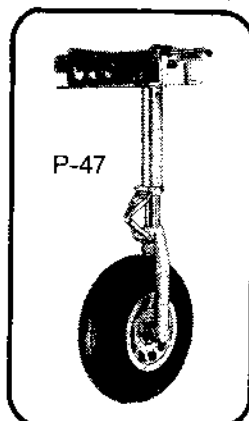

ENGINE REVIEW

assembly of the engine will be required since the crankshaft has to be withdrawn and this cannot be done without removing the cylinder head, extracting the cylinder liner and disconnecting the piston/conrod assembly from the crankpin. However, if experience with other engines employing toothed belts to drive their valve gear is any guide, belt wear should not be a problem.

One final point. If it should become necessary to disturb the toothed belt for any reason, it is, of course, important to make sure that the valve timing is correct on reassembly. There is a timing mark on the rim of the valve pulley. This must be rotated to the top or bottom position when the crankpin is at top dead center. It will be very obvious if the timing is wrong: misalignment by just one tooth will upset valve timing by some 24 degrees of crank rotation—easily visible by looking into the rear of the crankcase when the timing mark on the valve pulley is at the top or bottom position.

Peter Chinn, c/o *Model Airplane News*, 837 Post Rd., Darien, CT 06820. ■